

Gravity methods 1 - Key points

- ▶ [Gravitational attraction](#)
- ▶ [Gravity measurements](#)
- ▶ [Basic models](#) of gravity field
- ▶ [Gravity reduction](#)
 - ▶ [Corrections](#) and anomalies
 - ▶ Calibration, Drift, Latitude, Free air, Bouguer, and Terrain corrections
- ▶ [Relation of Bouguer gravity to topography](#)
 - ▶ Correlation and anti-correlation
 - ▶ Isostatically supported topography

- ▶ **Reading:**
 - ▶ Reynolds, Chapter 2
 - ▶ Dentith and Mudge, Chapter 3

Gravitational attraction

- ▶ In this course, we assume that you are familiar with the “Newton’s law of universal gravitation”
 - ▶ This law states that any two objects are pulled together by a force of attraction proportional to their masses and inversely proportionally to the square of their spatial separation:

$$F = G \frac{m_1 m_2}{r^2}$$

$G \approx 6.6726 \cdot 10^{-11} \text{m}^3/\text{kg}/\text{s}^2$ is the
“Universal gravitational constant”

- ▶ If one of these bodies is the Earth of mass M_{Earth} , then this downward-directed force vector (often called the weight) is

$$\mathbf{F} = m\mathbf{g}$$

where $g = |\mathbf{g}| = G \frac{M_{\text{Earth}}}{r^2}$

- ▶ The general goal of the gravity method is to measure small spatial variations of g and to invert them for variations in the distribution of mass within M_{Earth}

Physical meaning of \mathbf{g}

▶ What is the physical meaning of \mathbf{g} ?

- ▶ The unit of \mathbf{g} is acceleration (m/s^2), and consequently it is often called “**gravitational acceleration**” (e.g., Wikipedia or section 3.2 in Dentith and Mudge)
- ▶ However, I do not like this definition of \mathbf{g} as acceleration. “Acceleration” is a kinematic property of motion of some body, which is subject to various other conditions. For example, the acceleration of Newton's apple equals \mathbf{g} only when the apple is not affected by other forces. By contrast, in a common gravity meter, the action of \mathbf{g} is compensated by the elastic force of the spring, and we cannot talk about acceleration.
- ▶ **In reality, \mathbf{g} is** not acceleration but simply **the strength of gravity field**, analogously to \mathbf{E} in electrostatics. This strength is defined so that the gravity force acting on a **gravitational mass** m_g equals

$$\mathbf{F} = m_g \mathbf{g}$$

This is regardless of any other forces or acceleration, and m_g is analogous to electric charge q .

- ▶ If no other forces are acting on the body, it will obtain acceleration by the second Newton's law:

$$a = \frac{\mathbf{F}}{m_i} = \frac{m_g}{m_i} \mathbf{g}$$

where m_i is the **inertial mass**.

- ▶ The equivalence between m_i and m_g is a very interesting but separate question (answered in Einstein's theory of general relativity – **these masses are indeed equivalent**)

Values of g

- ▶ In SI units, the strength of gravitational field is measured in m/s^2 , and in gravimetry – in “Gal” (“Galileo”):

$$1 \text{ Gal} = \frac{1 \text{ cm}}{1 \text{ s}^2} = 0.01 \frac{\text{m}}{\text{s}^2}$$

- ▶ In these units, the “standard gravity (attraction on an “average” spherical Earth) is denoted g_0 and defined as

$$g_0 = 980.665 \text{ Gal}$$

- ▶ The typical range of interest in gravity variations is around tens of mGal (“milli-Gal”). In mineral exploration, a “gravity unit” simply denoted ‘gu’ is often used (Dentith and Midge):

$$1 \text{ gu} = 0.1 \text{ mGal}$$

- ▶ This unit has a simple practical meaning:

$$1 \text{ gu} = 1 \frac{\text{mm}}{\text{s}^2}$$

- ▶ In these lectures, **we will use mGal as the primary gravity unit**

Measurement of gravity

- ▶ The popular Lacoste Romberg relative gravimeter consists of a mass mounted on a freely pivoting beam supported at point O on the base of the instrument (Figure below). The mass is connected to point A above the support by a “zero-length spring”, which is constructed so that its elastic force is proportional to its total length L : $|F| = kL$

(The “zero-length spring” is constructed by using specially twisted wire or by combining pretensioned springs)

- ▶ By adjusting the distance z by rotating knobs on top of the instrument, the beam is leveled horizontally
- ▶ Due to the selected geometry (see figure), the vertical component of elastic force equals

$$|F| \cos \theta = k \frac{z}{\cos \theta} \cos \theta = kz$$

(note that it does not depend on θ , and so this angle is not important)

- ▶ The elastic force compensates the weight of the mass: $mg = kz$ and therefore g is obtained: $g = \frac{k}{m} z$
- ▶ Thus, small variations of g can be detected by precise measurement of the compensating vertical displacement of the upper end of the spring z

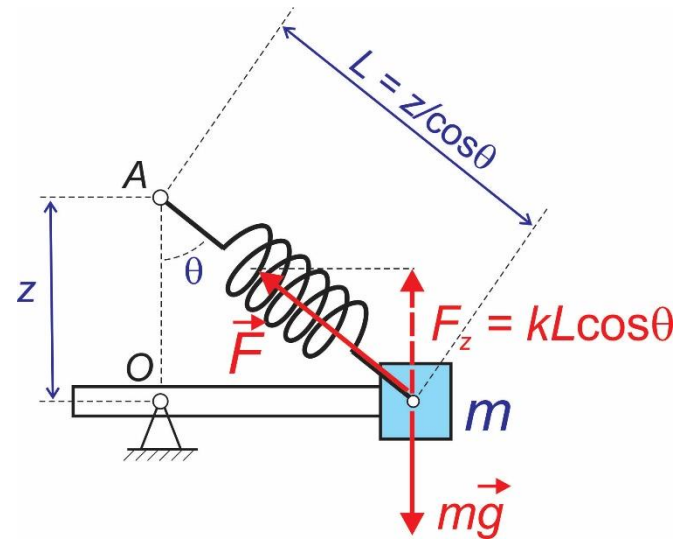

Lacoste-Romberg gravimeter

- ▶ This instrument performs **relative** gravity measurement, which means that the reported quantity (dial reading z) is measured relative to an arbitrary reference level. The scaling factor k/m is also arbitrary in practice
- ▶ The elasticity of the spring is sensitive to the operating temperature, barometric pressure, and ageing
- ▶ Because of the above reasons, this **gravimeter requires periodic calibration** by comparing the readings on its dial (basically, values of z) with absolute gravity values
- ▶ Prior to measurement, the instrument needs to be **carefully leveled on the ground**, for which an aluminum plate, bubble level, and leveling screws/knobs are used (picture on the right)

- ▶ **Side note:** Seismometers used for recording “long-period” waves and free oscillations of the Earth (ground oscillations resulting from large earthquakes, with periods from about 30 seconds to about an hour) are designed in the same way
 - ▶ For longest periods, the pivoting beam may be several meters long.



Leveling plate and knobs

Gravity reduction

- ▶ The measured gravity is modeled as a superposition of several effects shown below
 - ▶ **Models** of these predictable effects are called “**corrections**”:

Observed gravity = attraction of the reference ellipsoid of uniform average density (**figure of the Earth, g_0**)

- + effect of the atmosphere (**for some ellipsoids**)
- + effect of the elevation above sea level (**free air**)
- + effect if the “average” mass above sea level (**Bouguer and terrain**)
- + effect of sphericity of the Earth (**Bullard B**, for airborne gravity)

- + time-dependent variations (**instrument drift** and **tidal**)
- + effect of moving measurement platform (**Eötvös**)
- + effect of masses near the base of the crust that would support topographic loads (**isostatic**)
- + effect of variable density of the crust and upper mantle (“**geology**”)

If we model and subtract several of these terms from the data...

...then the remainder is the corresponding “anomaly” (for example, “free air” or “Bouguer” gravity)

- ▶ Subtraction of the above correction terms from the data is called “**gravity reduction**”

Gravity anomalies

- ▶ Gravity reduction consists in subtracting from the observed gravity one or several terms listed in the preceding slide. This subtraction removes (often strong) gravity effects of known structures and results in an “anomaly” (gravity signal unaccounted for by the known average structure)
- ▶ For example, the “Bouguer” anomaly is obtained from observed data g_{obs} as:

$$\Delta g_{\text{Bouguer}} = g_{\text{obs}} - g_{\text{free-air}} - g_{\text{Bouguer}} - g_0$$

where g_0 is some reference field value that we can ignore, and models for g_{Bouguer} and $g_{\text{free-air}}$ are discussed [later](#).

- ▶ To understand the effects of the various structures and corrections for them, in the following slides, we first consider models of three elementary structures:
 1. Flat sheet,
 2. Point mass or a sphere, and
 3. Linearly distributed mass or a cylinder.

Basic gravity model #1 - thin sheet

- ▶ Most corrections mentioned above are based on models of gravity produced by certain standard bodies. These models are easiest to derive from Gauss's law
- ▶ The simplest of these models is the thin sheet (often called **Bouguer slab**) Consider a uniform thin sheet of surface mass density $\sigma = M/A$
 - ▶ Because of symmetry, gravity is constant above and below the sheet and directed toward it (Figure below)
 - ▶ Enclose a portion of the thin sheet of area A in a closed surface. From Gauss's law, the total flux of g through the surface equals: $2gA = -4\pi G\sigma A$

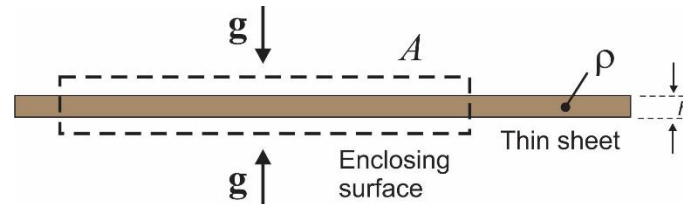

- ▶ Consequently, the **gravity above a thin sheet of mass** (and also below it, see figure) equals:

$$g = 2\pi G\sigma = 2\pi G \frac{M}{A} = 2\pi G\rho h$$

- ▶ where in the two additional forms of this formula, h is the thickness of the sheet and ρ is the usual density of the material

Basic gravity model #2 – point source or sphere

- ▶ A point of mass M is the typical way of thinking about a localized density anomaly within the subsurface
 - ▶ Similarly due to symmetry, gravity \mathbf{g} is constant at constant distance from the mass, and directed toward it
 - ▶ In this case, the surface used in Gauss's law, would be a sphere centered at the mass. The area of the sphere is $A = 4\pi r^2$ (right!), and therefore the Gauss's law gives:

$$g \cdot 4\pi r^2 = -4\pi GM$$

- ▶ Therefore, the **gravity at distance r from a point mass (and also from a hollow sphere or a spherical body with arbitrary dependence of density on radius)** equals (Newton's law of gravity):

$$g = G \frac{M}{r^2}$$

- ▶ In a more complete form including the center-directed orientation of vector \mathbf{g} , this formula is:

$$\mathbf{g} = -G \frac{M}{r^2} \hat{\mathbf{r}}$$

where $\hat{\mathbf{r}}$ is a unit vector pointing away from the mass.

Gravity outside and within spherical Earth

- ▶ The preceding relation for $\mathbf{g}(\mathbf{r})$ can be obtained from the potential U as $\mathbf{g} = -\nabla U$ (see the *Introduction* lecture), with U also depending on radius r only as

$$U = -G \frac{M}{r}$$

- ▶ This formula is good outside of the Earth where density $\rho = 0$. **Inside the Earth** ($r < R$, where R is the Earth's radius), only its spherical portion of radius r causes gravity, and therefore the gravitational acceleration \mathbf{g} is proportional to \mathbf{r} :

$$\mathbf{g} = -G \frac{M}{R^3} \mathbf{r} \quad \dots \text{and the potential:} \quad U = G \frac{M}{2R^3} r^2 + \text{const}$$

- ▶ Self-assessment question: Assuming all mass of a planet is concentrated on its surface, what is the gravity (\mathbf{g} and U) inside and outside of this planet?

Point or sphere below surface

- ▶ The point or spherical-body source is the typical model used for interpreting gravity data
 - ▶ In this case, only the **downward vertical component of g** from the preceding slide is measured, and it equals, in several forms (see Figure):

$$g = -g_z = GM \frac{\cos \alpha}{r^2} = \frac{GM}{H^2} \cos^3 \alpha = GM \frac{H}{r^3}$$

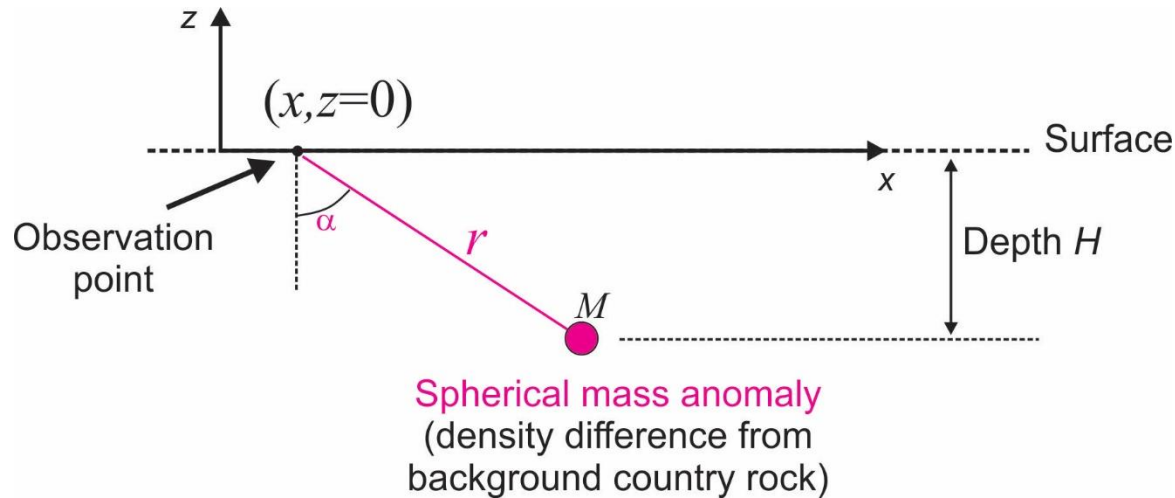

Basic gravity model #3 - line (pipe, cylinder) source

- ▶ This model is used to represent linear structures such as dikes
 - ▶ Consider a uniform thin rod of linear mass density γ
 - ▶ Enclose a portion of this rod of length L in a closed cylinder of radius r
 - ▶ Again from Gauss's law, the flux of \mathbf{g} through the cylinder is:

$$\mathbf{g} \cdot 2\pi r L = 4\pi G \gamma L$$

- ▶ Therefore, the gravity decays as $1/r$ with distance r from a line source (compared with $1/r^2$ for point source!):

$$\mathbf{g} = -\hat{\mathbf{r}} \frac{2G\gamma}{r}$$

- ▶ Vertical-component gravity measured on the surface (see Figure):

$$g = -g_z = 2G\gamma \frac{\cos \alpha}{r} = \frac{2G\gamma}{H} \cos^2 \alpha = \frac{2G\gamma}{H} \left(1 - \frac{x^2}{x^2 + H^2} \right)$$

- ▶ Accordingly, the potential increases logarithmically with r :

$$U = 2G\gamma \ln r + \text{const}$$

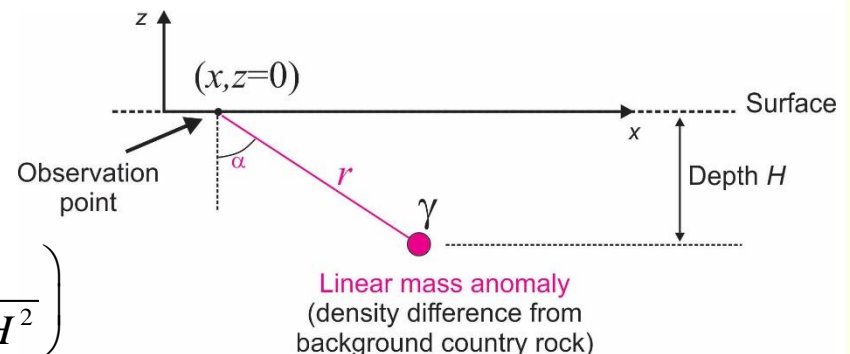

Basic gravity model #4 – a 2-D thin band

- ▶ This model is useful for modeling arbitrary 2-D structures, and it also has a similar 3-D extension. Note that the derivation is very simple if we use the concept of potential:
- ▶ Consider an arbitrary horizontal band of mass with **areal density** σ shown in the Figure below. If we split it into narrow strips of with dx , the **linear** density of each narrow strip will be $\gamma = \sigma dx$. From the last formula in the preceding slide, the measured g is a sum of $(-g_z)$ produced by the elementary strips:

$$g = -g_z = \int_{x_1}^{x_2} \left[\frac{2G(\sigma dx)}{H} \cos^2 \alpha \right]$$

Here, α is the inclination angle of the mass when viewed from the observation point

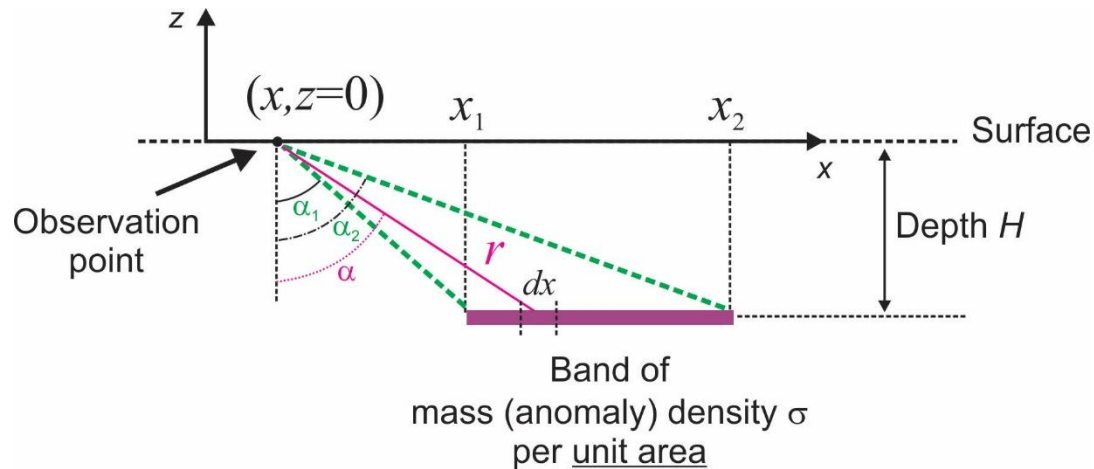

2-D thin band (continued)

- ▶ By expressing coordinates x through the inclination angle α , we have:

$$x = H \tan \alpha \quad \text{and} \quad dx = \frac{dx}{d\alpha} d\alpha = \frac{d\alpha}{\cos^2 \alpha}$$

and therefore the integral is simply (see Figure below)

$$g = \frac{2G\sigma}{H} \int_{x_1}^{x_2} (\cos^2 \alpha) dx = \frac{2G\sigma}{H} \int_{x_1}^{x_2} (\cos^2 \alpha) \frac{d\alpha}{\cos^2 \alpha} = 2G\sigma \int_{\alpha_1}^{\alpha_2} d\alpha = 2G\sigma (\alpha_2 - \alpha_1) = 2G\sigma \Delta\alpha$$

- ▶ Thus, the measured vertical-component gravity is proportional to the surface mass density σ **and angle $\Delta\alpha$ subtended by the band from the observation point.**
- ▶ Note that for an infinite thin slab, $\Delta\alpha = \pi$, and we have the formula $g = 2\pi G\sigma$ shown before.

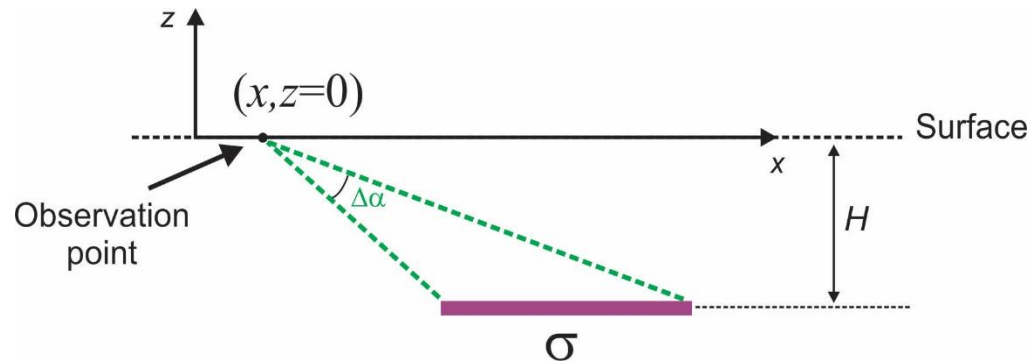

Basic gravity model #5 – thick sill with a vertical edge

- ▶ Consider a horizontal half-layer (sill) of arbitrary thickness and density contrast ρ
 - ▶ We want to know the position, shape, and width of its gravity anomaly on the surface, $g(x)$
- ▶ Consider a thin layer of thickness dz within the sill (purple below). Its surface density $\sigma = \rho dz$ and gravity (from preceding example):

$$g(x) = 2G\rho \operatorname{arccot} \frac{x}{z}$$

- ▶ The gravity of the sill is an integral:

$$g(x) = 2G\rho \int_{z_1}^{z_2} \operatorname{arccot} \frac{x}{z} dz$$

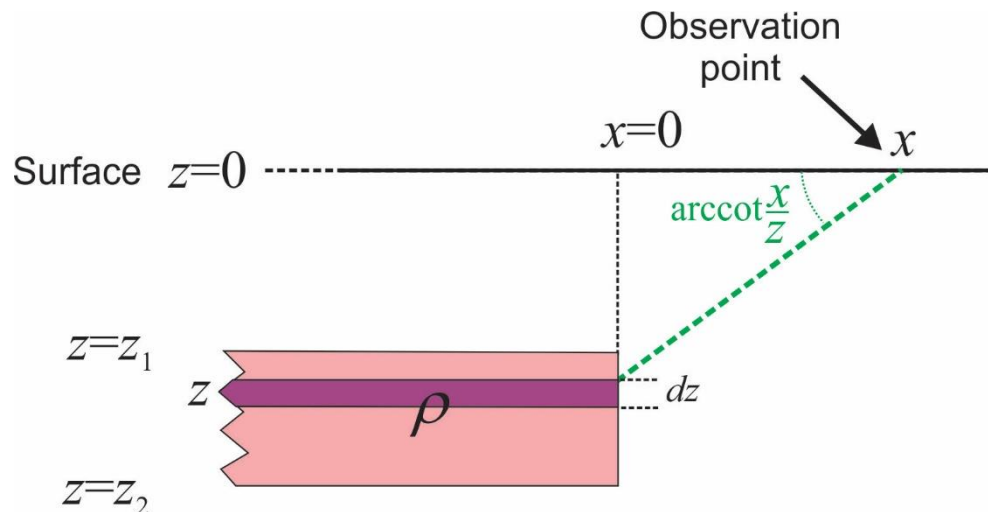

Thick sill (continued)

- The integral $\int_{z_1}^{z_2} \operatorname{arccot} \frac{x}{z} dz$ can be evaluated by replacing variable $u = z/x$

and integration by parts:

$$\begin{aligned}
 g(x) &= 2G\rho x \int_{z_1/x}^{z_2/x} \left(\operatorname{arccot} \frac{1}{u} \right) du = 2G\rho x \left[u \operatorname{arccot} \frac{1}{u} + \frac{1}{2} \ln(1+u^2) \right] \Bigg|_{u=\frac{z_1}{x}}^{\frac{z_2}{x}} = \\
 &= 2G\rho \left(z_2 \operatorname{arccot} \frac{x}{z_2} - z_1 \operatorname{arccot} \frac{x}{z_1} - \frac{x}{2} \ln \frac{x^2 + z_2^2}{x^2 + z_1^2} \right)
 \end{aligned}$$

Summary of basic models

- ▶ Note that the width of anomaly or range of transition in $g(x)$ corresponds to the depth to the target.

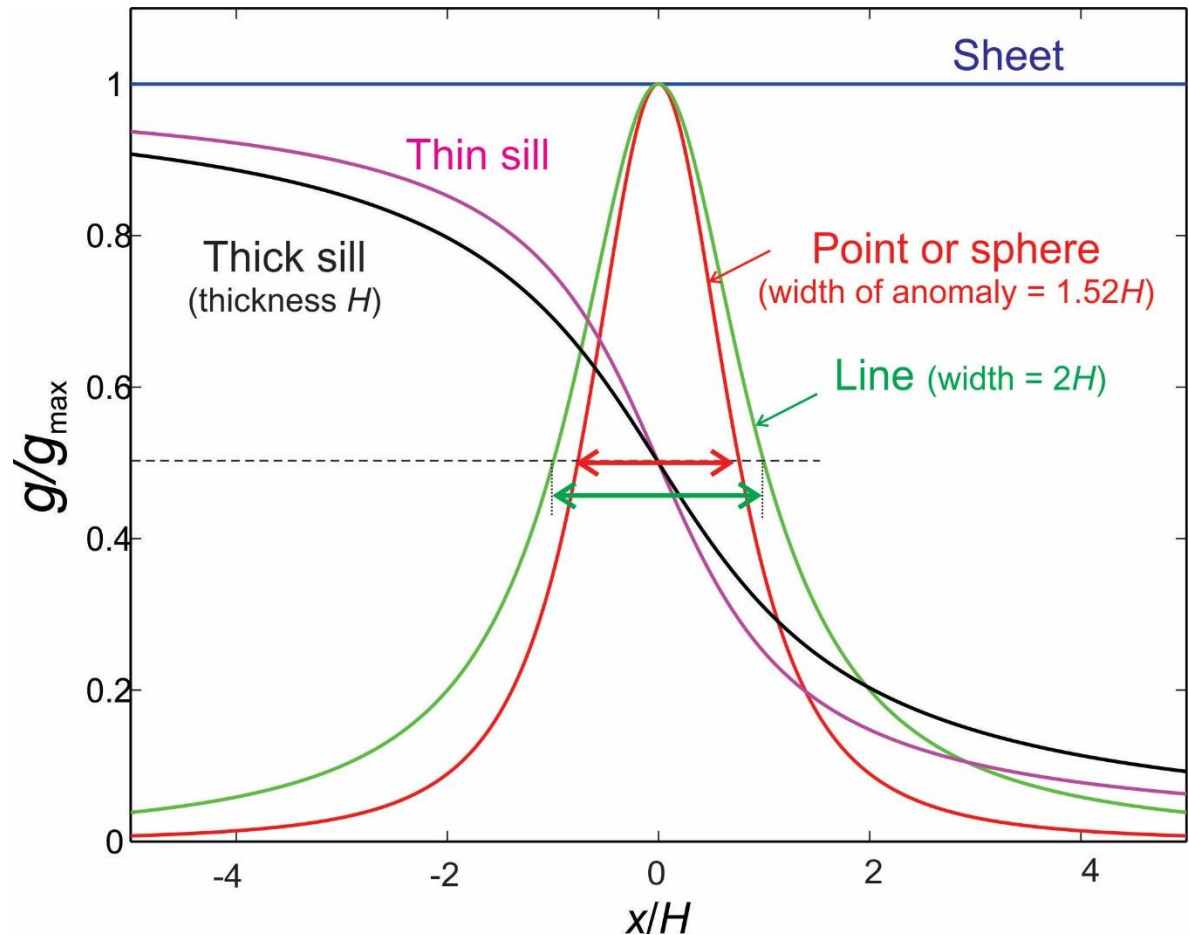

Gravity corrections

- ▶ In the following slides, we discuss several types of gravity corrections
 - ▶ Recall that “gravity corrections” represent models of known (often strong) effects which are subtracted from the measured data in order to clean up the small “anomalies” of interest

Gravity correction #1 – Calibration

- ▶ **Calibration** consists in transforming the readings on instrument dials into actual gravity values (mGal)
 - ▶ Calibration is the only correction involving multiplication of values. It is performed by interpolating the adjacent values in the **instrument calibration table**.
 - ▶ Here is a part of this table for our G267:

Counter reading	Value in mGal	Scaling factor for this interval
4300	4502.91	1.04853
4400	4607.77	1.04853
4500	4712.62	1.04848
4600	4817.47	1.04845
4700	4922.31	1.04844
4800	5027.16	1.04855
4900	5132.01	1.04855

Gravity correction #2 - Drift

- ▶ The largest correction is for the **drift** of the measured quantities with time. There are four major causes of such variations:
 1. **Effects of Earth's tides.** Because of gravitational attraction by the Moon and centrifugal force in the Earth-Moon system rotation, there are large gravity variations of about 0.1 mGal over 6 hours.
 - ▶ This is the largest drift (time-only related) effect, but it can be predicted within 0.01 mGal at most stations, and therefore it can be easily corrected for. In small and quick surveys, by returning to the **base station** often enough, tidal variations can be measured together with the other drift factors.
 2. **Instrumental drift.** Gravity instruments are extremely sensitive to their internal temperature, mechanical stress, and curing of springs, within the instrument.
 - ▶ For example, in the gravity meter we use in our field schools, we start warming it up about a week before operation, but the temperature keeps increasing for a couple weeks of the survey. As a result, the recorded values of gravity g show a downward trend with time.
 3. **Changes in barometric pressure** also affect the instrument., although its significance is significantly smaller (estimated as < 0.3 mGal). We usually treat this form of drift as part of the general, empirical time-related drift.
 4. **Operator errors.** Operator errors are also a sort of a “time” effect. This effect is corrected for by performing repeated measurements at some stations, and particularly at the selected **base station**.

Multi-year drift of our gravity meter

- ▶ During our field schools, the Lacoste Romberg G267 gravity meter usually drifts by $a_1 \approx 0.1\text{-}0.2$ mGal/day
- ▶ This drift is much larger than **the gravity variation this meter can see (0.01 mGal)**
 - ▶ Also note large variations in the readings (term a_0) after the instrument was serviced

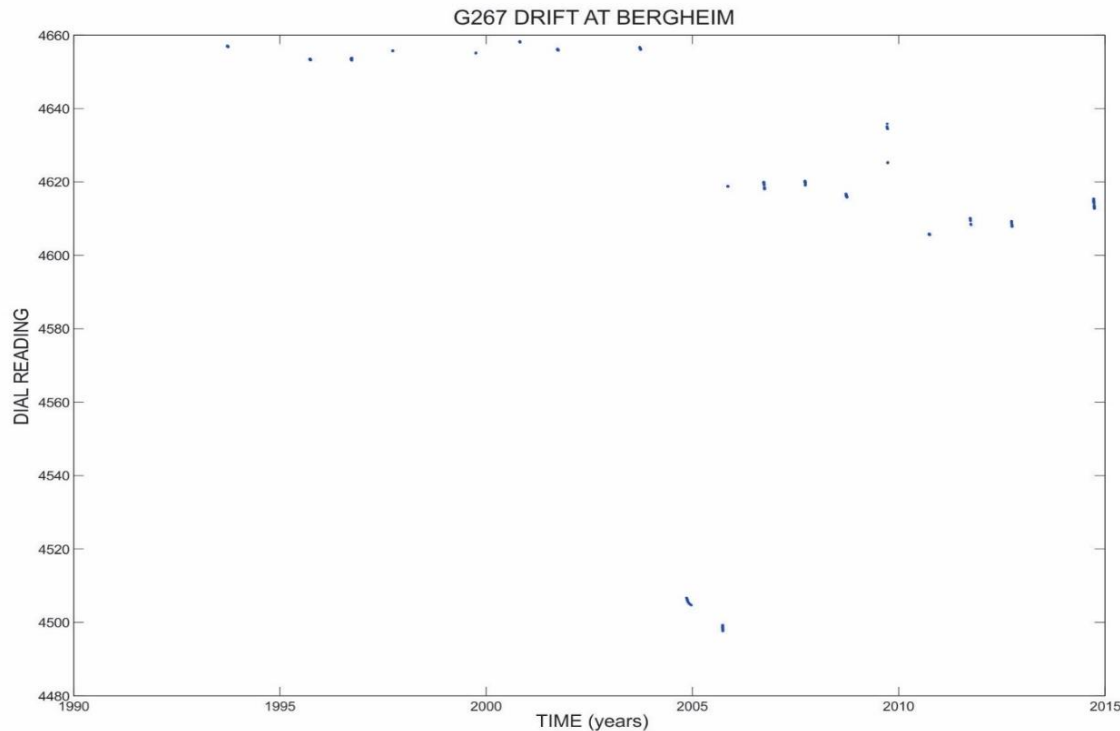

Data collection and plot by Jim Merriam

Drift model

- ▶ As any correction, drift correction should be based on some model for it. A model for drift can be given by a drift-noise term d dependent on observation time t_{obs} added to the gravity g_s at the current station:

$$u_s(t_{\text{obs}}) = g_s + d(t_{\text{obs}})$$

- ▶ For $d(t)$, some simple dependence is commonly used, such as a polynomial function:

$$d(t) = \sum_{k=1}^n a_k t^k + a_0$$

- ▶ To determine parameters a_k , the following procedure is used:
 - ▶ During data acquisition, periodically (every 1-2 hours) return to the **base station** the base station and perform multiple **repeated readings** there. Also, start and end each survey day at the base station.
 - ▶ By fitting readings at the base station as function of time, invert for a_k by using various more or less sophisticated methods such as **interpolation** or the **Least Squares**.

Gravity drift from UofS geophysics field school

- ▶ Example of (mostly tidal) drift measured over 5 hours of recording
 - ▶ Periodically repeating measurements at the **base station** (at UofS test site) and another “new base” (symbols with error bars) to form the drift curve (blue and red line)

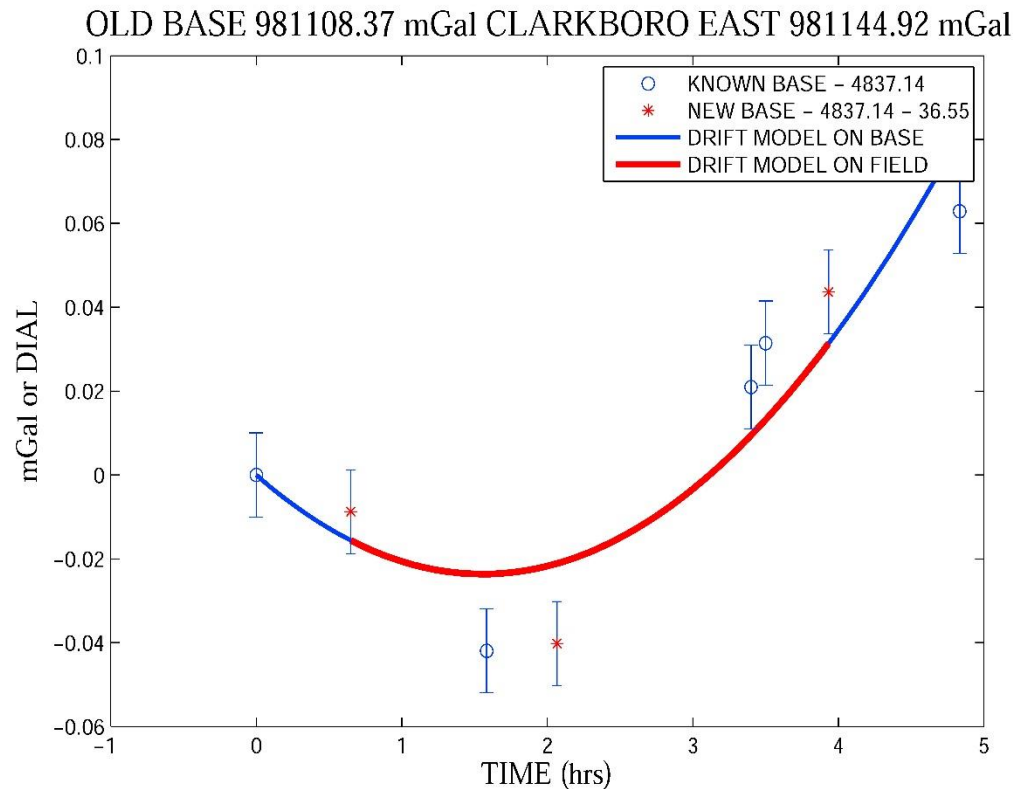

Data collection and plot by Jim Merriam

Gravity correction #3 – Latitude

- ▶ For a uniform Earth, gravity is the lowest at the equator and increases with latitude. This increase is caused by two reasons:
 - ▶ **Centrifugal force** due to rotation of the Earth. This force acts as additional gravity g_c directed upward, away from the rotation axis, and increasing as $\sin^2(\theta)$, where θ is the colatitude (90 degrees minus latitude)
 - ▶ Because of the same centrifugal force, the distance from the center of the Earth is greater at the equator, and consequently the gravitational attraction is weaker.
- ▶ The amount of this reduction can be accurately calculated for any reference ellipsoid (approximation for the shape of the rotating Earth). For example, for the “IGF30” reference, the latitude effect is (in mGal/radian):

$$\frac{\partial g}{\partial \theta} = -978.049 \times (0.0052884 \sin 2\theta + 0.0000118 \sin 4\theta)$$

- ▶ At latitude = colatitude 45° , this variation of gravity gives the **latitude correction**

$$g_{\text{lat}} = -0.8118 \left[\frac{m\text{Gal}}{km} \right] \times s [km]$$

- ▶ where s is the southward distance from the base station in km
- ▶ Thus, **the latitude effect is large, even in small surveys.**

Gravity correction #4 – Free Air

- ▶ The “free air” correction is simply **correction for elevation (height) of the observation point** above the global reference surface called “**the geoid**”. Roughly, the geoid is the mean sea level.
- ▶ The elevation effect is readily obtained from the formula for the gravity field of the sphere (earlier in this lecture):

$$g(r) = G \frac{M}{r^2}$$

- ▶ Therefore, the change of g due to an increase of elevation $\Delta r = \Delta h$ equals

$$g_{\text{free-air}} \approx -2G \frac{M}{r^3} \Delta r = -2g \frac{\Delta r}{r}$$

- ▶ For practical estimates, this gives with good accuracy:

$$g_{\text{free-air}} \approx -0.3086 \left[\frac{mGal}{m} \right] \times \Delta h [m]$$

- ▶ where Δh is the variation of elevation of the observation point in meters

Importance of the free-air (elevation) effect

- ▶ The “free-air” gradient of gravitational attraction imposes stringent requirements on the accuracy of the coordinates in a gravity survey
- ▶ In most common gravity meters, the reading sensitivity is about 0.01 mGal. From the formula in the preceding slide, $\Delta g_{\text{free-air}} = 0.01 \text{ mGal}$ for $\Delta h \approx 3 \text{ cm}$.
 - ▶ Thus, **measurements of ground elevation must be quite accurate in gravity surveys.**

Gravity correction #5 - Eötvös

- ▶ The Eötvös correction is necessary when measuring gravity on a moving platform like a vehicle, ship, or an airplane
- ▶ The Eötvös gravity is caused by the Coriolis force, which is due to the rotation of the Earth and acts like a gravity force directed perpendicular to both the direction of motion and Earth's axis.
 - ▶ Similar to free-air and tidal gravities, this force is predictable with great accuracy. The formula for the vertical component of this force (which affects gravity measurements) is:

$$g_E(r) = -2\omega V \cos \lambda \sin \alpha - \frac{V^2}{R_E}$$

- ▶ where V is the speed of the moving platform, R_E is the distance from the center of the earth, ω is the angular rotation velocity, λ is the latitude, and α is the angle between the direction of motion and the true north.

Importance of Eötvös correction

- ▶ In the formula on the preceding slide, the first term is basically the additional centrifugal force due to the movement of the platform in the direction of rotation. Both of these forces are often large:
 - ▶ For an airplane moving east along the equator ($V = 100$ m/s, $\lambda = 0$, $\alpha = 90^\circ$), the first term equals 1454.4 mGal, and the second term is 156.99 mGal.
 - ▶ These values are huge for gravity measurements, and so the heading direction and speed of the aircraft needs to be known very precisely.
 - ▶ For a ship moving at 5 m/s, these terms are 72.27 mGal and 0.39 mGal, respectively.
 - ▶ These are also significant forces, and the heading of the ship also needs to be precisely known when doing gravity measurements

Gravity correction #5 – Bouguer

- ▶ The “**Bouguer**” correction accounts for the **gravitational attraction of a uniform flat slab of rock** between the reference geoid and the observation position
- ▶ The gravity of a uniform flat layer of thickness H is readily obtained from the first “basic model” in this lecture:

$$g_{\text{Bouguer}} = 2\pi G \rho H$$

- ▶ With a mean crustal density of $\rho = 2.67 \text{ g/cm}^3$, this effect is

$$g_{\text{Bouguer}} = 0.1119 \left[\frac{mGal}{m} \right] \times H [m]$$

- ▶ Thus, **Bouguer correction is about 40% (and opposite sign) of free-air one**
- ▶ Bouguer correction (subtraction of g_{Bouguer} from data) can be understood as “removal” of a flat layer of uniform rock beneath the point of recording.
 - ▶ Together with the free-air correction, Bouguer correction produces an effective observation on the surface of the reference geoid without topography
 - ▶ Thus, after these corrections, the remaining features in the data should be due to subsurface anomalies

Bullard corrections

- ▶ The flat-slab Bouguer correction is sometimes also called the “**Bullard A**” correction
- ▶ At large elevations (in airborne surveys), sphericity of the Earth becomes important. The Bouguer correction is then complemented with **sphericity** (“**Bullard B**”) correction (you will see its form in GEOL481)

Gravity correction #6 – Terrain

- ▶ The “**Bouguer**” correction assumes a uniform density below the observation level
- ▶ Therefore, it overestimates the attraction of the valleys below this level and upward “pull” of the mountains above it (Figure).
- ▶ Therefore, the effect of terrain topography differs from g_{Bouguer} by some $g_{\text{terrain}} < 0$. The “**complete Bouguer**” correction is given by:

$$\Delta g_{\text{complete Bouguer}} = g_{\text{obs}} - g_{\text{free-air}} - g_{\text{Bouguer}} - g_{\text{terrain}} - g_0$$

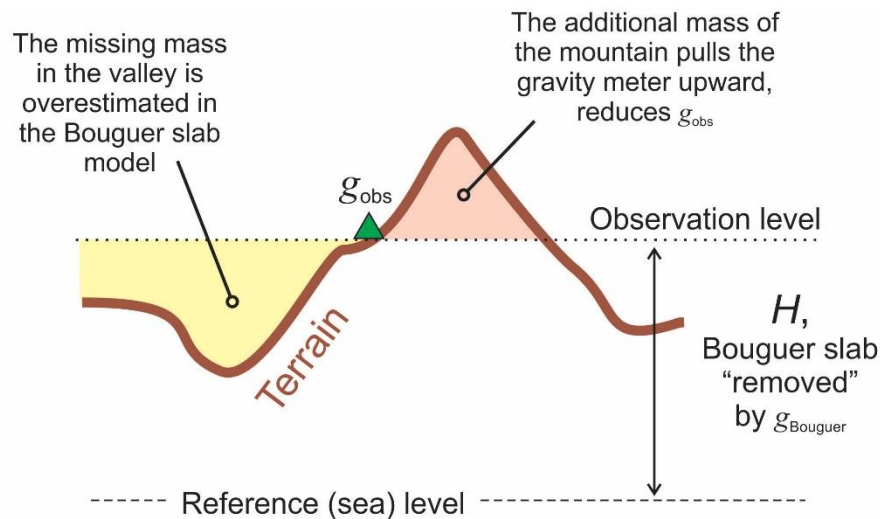

$g_{\text{terrain}}(x,y)$ is usually modeled from digital maps of surface topography by integrating “basic solutions” like those described at the beginning of this lecture

(Un)correlation of Bouguer gravity with topography

- ▶ Generally, after proper Bouger and terrain corrections, we expect gravity anomalies to be related to structures at depth and **uncorrelated with topography**.
 - ▶ In the next lecture, we will use this principle for estimating terrain density.
- ▶ However, in some cases, this uncorrelation is not the case. Usually, we have a lower-density layer (for example, Earth's crust) overlaying a denser rock (mantle). Then, depending on the thickness of this layer, there are three different cases:
 1. The overburden layer is of constant thickness. In this case, the layer has almost no effect on gravity anomalies observed on the surface, and the measured gravity is due to the deeper crust.
 2. The overburden thickness **anti-correlates** with surface topography (bedrock is shallower at high elevations). In this case, Bouguer correction does not remove the effect of elevation completely, and the Bouguer gravity **is positively correlated with topography**
 3. The overburden thickness **correlates** with surface topography. In this case, the Bouguer gravity **is negatively (or anti-) correlated with topography**. An important example of this case is the isostatically-supported crustal topography discussed in the next slides

Large-scale correlations of gravity with topography

- ▶ Look at the Bouguer-corrected gravity map of Canada below. There is a large negative gravity anomaly over the high-topography Rocky Mountains (purple) and significant positive anomaly over the continental shelves (yellow)
- ▶ This occurs because the large-scale topography (at > 100 -km scales) is **isostatically supported**. This case is discussed in the next slide.

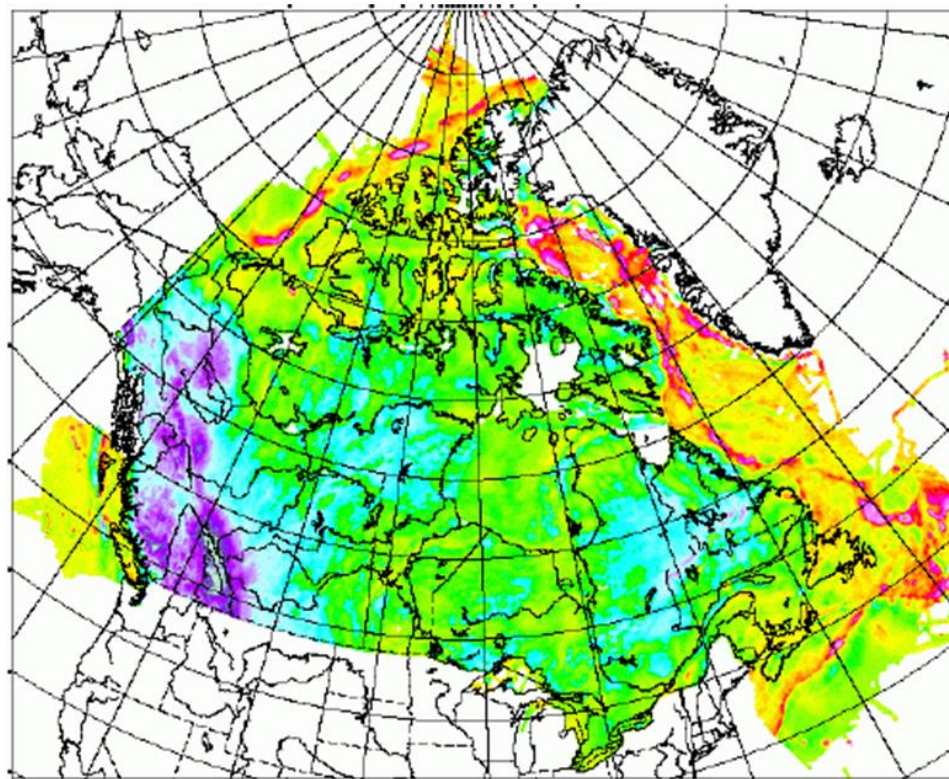

Isostatically supported topography

- ▶ For a perfectly isostatically compensated crust, high surface topography is supported by buoyancy of a large crustal root (Figure below)
- ▶ The condition of buoyancy means that above a certain compensation level (dashed line), **the weight (and therefore mass) of the rock column is the same at all locations**
- ▶ From our derivation of Bouguer gravity above, this constancy of mass means that **the gravity above an isostatically-supported crust is constant regardless of its topography and subsurface structure**

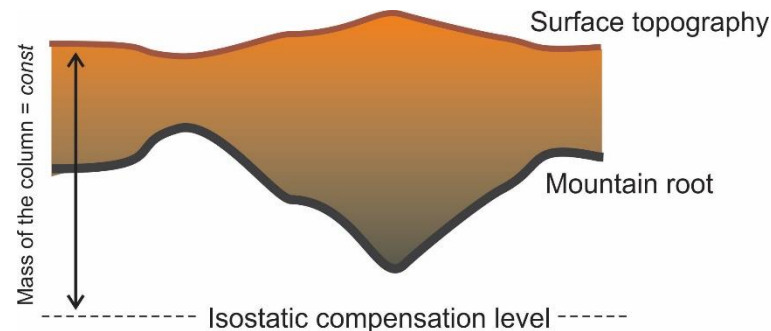

- ▶ Thus, **for isostatically-supported structures, it is better to look at free-air corrected images, and Bouguer correction over-corrects the observed gravity**
 - ▶ For partial isostatic compensation, the effect of the mass at the base of the buoyant layer can be included in a separate **isostatic gravity correction**